

Digital information in user satisfaction mediated by digital inclusion in university students in extreme economic situation

Olger Gutierrez-Aguilar, Doctor¹, Victoria Torres Cheje de Manchego, Doctora¹, Angela Calisaya-Gutierrez MSc² y Sandra Chicaña-Huanca MSc¹

¹ Universidad Católica de Santa María, Arequipa-Perú

² Universidad Nacional de San Agustín, Arequipa-Perú

ogutierrez@ucsm.edu.pe, vtorresc@ucsm.edu.pe, acalisayagu@unsa.edu.pe, schicanah@ucsm.edu.pe

Abstract— The research sought to ascertain the relationship between digital information, which includes the exchange of digital information, information exchange, information need, and information search, as predictor variables in user satisfaction, and digital inclusion as a mediating variable. The methodology for the study follows a non-experimental research design; an electronic questionnaire (n = 30; = 0.959; = 0.959) is administered to a sample of 233 university students from a public university in southern Peru under harsh economic conditions, using reliability and validity tests, factor analysis, and structural equation modeling with partial least squares. The results have shown a statistically significant effect between digital inclusion and satisfaction among university students in extreme poverty, and the levels of satisfaction and user satisfaction maintain a close dependency relationship. The exchange of information positively influences digital inclusion in the same way, that information search maintains a statistically significant relationship.

Keywords— Digital inclusion, Exchange of digital information, Exchange of information, Information need, Information search, User satisfaction.

I. INTRODUCTION

Digital information resources have become critical tools for the development of educational activities in university students; the amount of digital information that is generated every day in the universal context allows the user unlimited access to data and information, it is so that the development of skills related to critical thinking, allows the user of the information to discriminate the reliability of the data and information for academic work, in such a way that, carry out transformation processes, which allow us to understand how to face the new educational scenarios [1]; But many students in Peru who live in extreme poverty have trouble doing many things, like getting on the Internet. In Peru, a system called the Household Targeting System (SISFOH) keeps track of people's socioeconomic information for social programs and government aid [2]. In this context, the limitations caused by COVID-19's effect of cutting people off from their friends and family are added. Therefore, the situation of public university students became a critical problem in coping with educational tasks, which today require acceptable levels of digital skills to give a more qualified response to the search, access, and selection of digital information [3].

Digital information brings different skills related to the exchange of digital information, the exchange of information, information need, information search, and the use of information in such a way that digital inclusion is more latent today than ever. Getting good at these skills related to digital information makes it possible to use the information in a way that users can be happy with [4].

Also, the digital inclusion that is part of the new skills of university students and teachers for the implementation of different methods related to the completion of collaborative projects allows for flexible and open teaching, which helps students do more independent work by giving them more control over how they learn [5].

Recent research shows that students access the Internet from home, although a small part does so from school, public places, or other people's homes [6]. According to Díaz-García et al., Information and Communication Technologies (ICT) represent a change in the learning methods of university students [7]. Therefore, social reality requires that ICT training be part of compulsory education to make rational, critical and safe use of these technologies since the risks they entail cannot be ignored [8].

The importance of the exchange of digital information lies in the use of digital technologies with a wide range of application possibilities; that is, they are multiple and diverse [9], especially in collaborative activities through online learning networks such as the Web Quest, wikis, forums, blogs, web pages, chats, Facebook groups [10] [11]. The use of information through the Internet has a big impact on how education is rethought so that students can learn more and work together with their classmates, which is mediated by affectivity [12].

Social communities today, through the Internet, favour the publication of content, information sharing, and self-learning [13]. Otherwise, García & González [14], warn that university students exchange information through emails, chat, and the learning management system (LMS) such as Moodle or Blackboard. Creating and sharing scholarly products means making documents or scholarly products with web tools and sharing them with teachers or peers through shared folders [15]. So, it is important to stress that it is not just about sharing and passing on information but also about turning it into knowledge [14].

The use of tools related to the Internet and social networks is directly linked to the use of information in education today. These tools are valuable and easy to use, making students feel good. These would influence school satisfaction [16] especially in this sense. It is a common fact in today's society that they are part of people's lives, especially the lives of young university students. Knowing how they use these tools and how they feel about them allows you to create a profile of a university student [17].

The performance of academic tasks such as the preparation of online reports through collaboration software, making corrections to work done, and obtaining educational material will be possible through collaborative activities in the efficient use of digital information, such as the exchange of digital information, exchange of information, information need, and information search [15]. Likewise, to verify the data, they indicate that students use digital technology primarily in academic projects and can use ICT for information management, developing critical thinking, solve problems, and handling mobile devices [18].

Regarding user satisfaction, students who develop high degrees of self-determination to achieve learning have a positive perception of their academic self-efficacy and high levels of satisfaction with the academic experience [19], thus, the authors infer that developing high levels of enjoyment and satisfaction from academic activities affects the development of a positive perception of the abilities to achieve learning outcomes successfully. Student satisfaction is closely related to teacher performance [20] and other influential factors in perceived learning mediated by satisfaction [21], in addition to being related to the efficiency of educational processes and other factors. Intervening, such as cultural, social, and economic-financial, is vital for academic performance success. Likewise, the management and improvement of the quality of higher education in a global environment [22]. Regarding the first, some studies indicate that students of a high socioeconomic level tend to process information about their capacity more effectively, representing a disadvantage in information processing compared with students from lower strata [23].

Digital inclusion significantly predicts quality of life and vice versa [24] A school's ability to guarantee students' educational experiences with digital technologies implies practices to promote and include a digital infrastructure. Competence and confidence in the use and skills of teachers and students with digital technology are essential elements [25]. Access to affordable ICTs can help people become more digitally included and improve their quality of life [26]. Although digital inequalities and divides exist in countries, communities, and among the people left behind or disadvantaged, little attention is paid to what works to alleviate these inequities and divisions in various cultural contexts [27]. Therefore, support must be shown for the mediating effects of ICT use in the links between digital inclusion and quality of life [26]. Therefore, based on the above arguments, the following hypotheses are adopted:

H1 There is a statistically significant effect between digital inclusion (ID) and satisfaction (S).

H2 There is a statistical relationship between the exchange of digital information (DIE) and digital inclusion (ID).

H3 The exchange of information (ISH) positively influences digital inclusion (ID).

H4 Information need (IN) has a statistically significant relationship with digital inclusion (ID).

H5 The information search index (IS) has a statistically significant relationship with digital inclusion (ID).

H6 The satisfaction (S) is related to user satisfaction (USAT).

H7 The use of information (IUS) positively influences digital inclusion (ID).

II. METHODOLOGY

A sample of 233 students from the National University of San Agustín de Arequipa, Peru, from the first to fifth year of university studies in professional careers was used for this study: arts, communication sciences, accounting, economics, mechanical engineering, and psychology. The students were selected according to the SISFOH file (Household Targeting System), which enables the qualification of poor and impoverished students in Peru, who are 43.3% men and 56.7% women, whose ages range from 16 to 24 years. The total mean was 20.00 (SD=2.692). The instrument application took place virtually in 2021 in full quarantine as a restrictive measure to avoid COVID-19 contagion.

The tool is based on the one used in Ransome Epie Bawacka and Jean Robert Kala Kamdjoug's study, The role of digital information use on student performance and collaboration in marginal universities [28]. Online surveys were used to get the information, and teachers from the professional schools involved were very involved.

With a sample of 80 students in a preliminary study to find out how reliable it was, the instrument was validated and approved for research, which led to the following: Cronbach's alpha $\alpha = 0.959$ and McDonald's coefficient $\omega = 0.959$ The Kaiser-Meyer-Olkin coefficient (KMO = 0.924) indicates a good fit of the items analyzed with their factor when determining the fit of the items with their corresponding factors. Bartlett's sphericity test had the following results: $\chi^2 = 5957.034$; $df = 666$ and following; $p < 0.000$, whose assessment is reasonably significant. The statistical calculations were performed using the software Smart PLS (version 4.0) and JASP (version 0.17).

III. RESULTS

For the factor analysis, the following variables were codified: digital inclusion (ID), exchange of digital information (DIE); exchange of information (ISH), information need (IN), information search (IS), satisfaction (S), use of information (IUS) and user satisfaction (USAT).

The calculation was performed with SmartPLS using the PLS (Partial Least Squares) algorithm, which has a regression

structure in terms of weight vectors, with the following adjustments: a maximum iteration of 300 and a stopping criterion of $(10^{-X})^7$. Table I presents the matrix of external loads with their respective values, using items with acceptance coefficients ≥ 0.700 as cut-off criteria

TABLE I
EXTERNAL LOADS - SMART PLS

	ID	DIE	ISH	IN	IS	S	IUS	USAT
DIE2		0.851						
DIE3		0.941						
DIE4		0.876						
ID3	0.773							
ID4	0.917							
ID5	0.918							
IN1				0.836				
IN2				0.837				
IN3				0.869				
IS3					0.796			
IS4					0.859			
IS5					0.876			
IS6					0.769			
ISH1			0.825					
ISH3			0.871					
ISH4			0.879					
ISH5			0.865					
IUS1							0.875	
IUS2							0.883	
IUS3							0.821	
IUS4							0.884	
S1						0.888		
S2						0.899		
S3						0.906		
USAT1								0.832
USAT2								0.885
USAT3								0.838
USAT4								0.852
USAT5								0.783
USAT6								0.865

Taking into account the correlation coefficients in all its dimensions, the reliability and construct validity are expressed in Cronbach's alpha, and the results vary between 0.807 and 0.918, which is acceptable. The coefficient (ρ_A) is used to verify the reliability of the values obtained in the construction and design of the PLS [29]; the results in (ρ_A) as an acceptance criterion should be greater than 0.7 to demonstrate composite reliability, but the results vary between 0.832 and 0.920. The application of the composite reliability criterion is required [30], in such a way that the acceptance criterion is

determined that its values exceed 0.6, so that reasonable levels of reliability and internal consistency are demonstrated for each of the variables, resulting in values ranging between 0.896 and 0.936. The values of the average variance extracted Average Variance Extracted (AVE) are between 0.683 and 0.805, results that exceed the recommended minimum value of 0.500 [31]; therefore, it is concluded that convergent validity is acceptable in its model components. As seen in Table II.

TABLE II
ASSESSMENT OF THE MEASUREMENT MODEL FOR REFLECTIVE CONSTRUCTS

	Cronbach's Alpha	ρ_A	Composite reliability	Average variance extracted (AVE)
Digital Inclusion ID	0.843	0.880	0.904	0.761
Exchange of Digital Information DIE	0.870	0.920	0.919	0.792
Exchange of information ISH	0.883	0.884	0.919	0.740
Information Need IN	0.807	0.832	0.884	0.718
Information Search IS	0.845	0.855	0.896	0.683
Satisfaction S	0.879	0.881	0.925	0.805
Use of Information IUS	0.890	0.911	0.923	0.750
User Satisfaction USAT	0.918	0.920	0.936	0.711

The discriminant validity of the model was tested using the criterion proposed by Fornell and Larcker [32] and [33], which states that the square root of AVE in each variable's resulting values should be more significant than the findings of the correlation among the variables studied. This result shows that discriminant validity is well established. See Table III.

TABLE III
FORNELL-LARCKER CRITERION

	ID	DIE	ISH	IN	IS	S	IUS	USAT
ID	0.872							
DIE	0.153	0.890						
ISH	0.322	0.397	0.860					
IN	0.142	0.505	0.418	0.847				
IS	0.331	0.400	0.542	0.476	0.826			
S	0.533	0.306	0.404	0.216	0.408	0.897		
IUS	0.251	0.602	0.55	0.588	0.616	0.435	0.866	
USAT	0.295	0.477	0.636	0.521	0.572	0.508	0.759	0.843

Henseler, CM Ringle, and M. Sarstedt [34] came up with a different way to show discriminant validity using the heterotrait-monotrait relationship (HTMT). The HTMT coefficient was used in this way because of the results, which are valid because their values are below the (<0.90) [35]. See Table IV.

TABLE IV
HETEROTRAIT CRITERION - MONOTRAIT - HTMT

	ID	DIE	ISH	IN	IS	S	IUS	USAT
ID								
DIE	0.162							

ISH	0.359	0.446						
IN	0.161	0.607	0.502					
IS	0.382	0.474	0.627	0.589				
S	0.608	0.338	0.458	0.254	0.472			
IUS	0.278	0.678	0.621	0.708	0.717	0.490		
USAT	0.329	0.528	0.708	0.609	0.648	0.562	0.842	

Figure 1 Model R² - SmartPLS.

Figure 1 and Table VII show the results of the coefficient of determination R² and the hypothesis tests using bootstrapping test results, where ID has a positive effect on S (β ID→S = 0.533, t = 10.473, p < 0.000), which supports the H1; DIE has a positive effect on ID (β DIE→ID = -0.01, t = 0.125, p < 0.450), values that do not support H2; ISH has a positive effect on ID (β ISH→ID = 0.208, t = 2.553, p < 0.005), values that support H3; IN has a positive effect on ID (β IN→ID = -0.076, t = 1.021, p < 0.154), values that do not support H4; IS has a positive effect on ID (β IS→ID = 0.23, t = 2.999, p < 0.001), values that support H5; S has a positive effect on USAT (β S→USAT = 0.508, t = 9.427, p < 0.000), values that support H6; IUS has a positive effect on ID (β IUS→ID = 0.045, t = 0.447, p < 0.238), values that support H7.

According to the proposed structural model, the exogenous variables—exchange of digital information, information need, exchange of information, information search, and the use of information—would exert a level of influence on the endogenous variable related to digital inclusion by 14.2% (R² = 0.142) of the explained variance, which is equivalent to sustaining that there would be other exogenous variables that would explain the nature of the endogenous variable by 85.8% and that are not part of the model. Similarly, digital inclusion as an exogenous variable has a statistically significant effect on satisfaction with an R² of 0.284, which is equivalent to 28.4% of the variance explained by the model; similarly, the satisfaction variable as an exogenous variable has a significant relationship with an R² of 0.258, which is equivalent to 25.8% of the variance explained by the model. See Figure 1.

Table V presents the significant indirect effects obtained through the bootstrapping resampling test. The proposed model establishes the P-value (p < 0.05) as the acceptance criterion for the level of statistical significance. This is equivalent to sustaining that the proposed model presents mediation variables.

TABLE V
SIGNIFICANT INDIRECT EFFECTS MATRIX (P<0.05)

	Original sample (OR)	Sample mean (M)	Standard deviation (STDEV)	t-Statistics (O/STDEV)	P Values
Digital Inclusion ID -> Satisfaction S -> User Satisfaction USAT	0.271	0.274	0.043	6.297	0.000
Information Search IS -> Digital Inclusion ID -> Satisfaction S	0.123	0.124	0.044	2.773	0.003
Exchange of information ISH -> Digital Inclusion ID -> Satisfaction S -> User Satisfaction USAT	0.056	0.059	0.026	2.173	0.015
Information Search IS -> Digital Inclusion ID -> Satisfaction S -> User Satisfaction USAT	0.062	0.064	0.024	2.58	0.005
Exchange of information ISH -> Digital Inclusion ID -> Satisfaction S	0.111	0.114	0.046	2.416	0.008

Because some variables in the structural model do not fulfil their mediation role, they are not significant according to the P-value acceptance criterion (p < 0.05). Hence, their results exceed the level of significance. That is, (p > 0.05). Table VI presents the results obtained.

TABLE VI
NON-SIGNIFICANT INDIRECT EFFECTS MATRIX (P>0.05)

	Original sample (OR)	Sample mean (M)	Standard deviation (STDEV)	t-Statistics (O/STDEV)	P Values
Use of Information IUS -> Digital Inclusion ID -> Satisfaction S -> User Satisfaction USAT	0.012	0.011	0.029	0.425	0.335
Exchange of Digital Information DIE -> Digital Inclusion ID -> Satisfaction S	-0.005	-0.005	0.043	0.125	0.450
Use of Information IUS -> Digital Inclusion ID -> Satisfaction S	0.024	0.021	0.055	0.435	0.332
Information Need IN -> Digital Inclusion ID -> Satisfaction S -> User Satisfaction USAT	-0.020	-0.015	0.021	0.980	0.163
Information Need IN -> Digital Inclusion ID -> Satisfaction S	-0.040	-0.030	0.041	0.990	0.161
Exchange of Digital Information DIE -> Digital Inclusion ID -> Satisfaction S -> User Satisfaction USAT	-0.003	-0.003	0.022	0.123	0.451

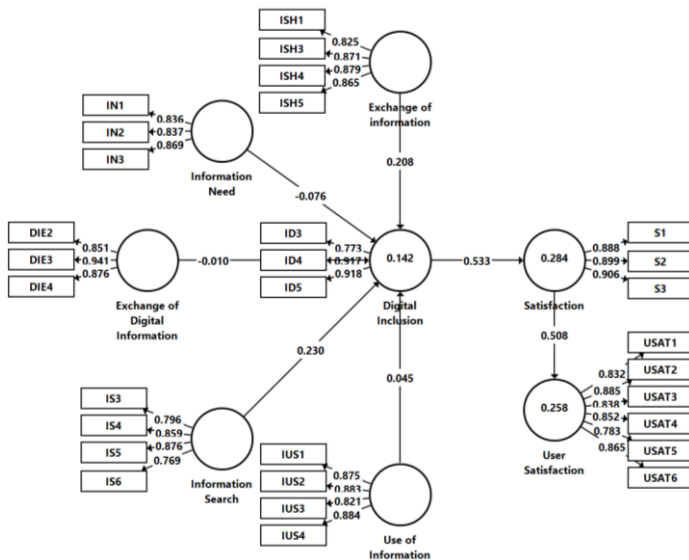

The results of the bootstrapping test are shown in Table VII. This technique involves estimating the model parameters for each of the 10,000 resamples, replacing the original sample, and comparing the outcomes. The standard deviation of the estimates from the bootstrap method is used to calculate the standard error of an estimate. The other hypotheses are accepted, while hypotheses H1, H3, H5 and H6 are rejected as hypothesis H2, H4 and H7 due to the significance level for the P-Value ($p < 0.05$).

TABLE VII
BOOTSTRAPPING TEST RESULTS

Hypothesis	Original sample (OR)	Sample mean (M)	Standard deviation (STDEV)	t-Statistics (O/STDEV)	P Values
H1 Digital Inclusion ID -> Satisfaction S	0.533	0.535	0.051	10.473	0.000
H2 Exchange of Digital Information DIE -> Digital Inclusion ID	-0.01	-0.008	0.082	0.125	0.450
H3 Exchange of information ISH -> Digital Inclusion ID	0.208	0.212	0.082	2.553	0.005
H4 Information Need IN -> Digital Inclusion ID	-0.076	-0.057	0.074	1.021	0.154
H5 Information Search IS -> Digital Inclusion ID	0.23	0.23	0.077	2.999	0.001
H6 Satisfaction S -> User Satisfaction USAT	0.508	0.511	0.054	9.427	0.000
H7 Use of Information IUS -> Digital Inclusion ID	0.045	0.040	0.100	0.447	0.328

IV. CONCLUSIONS

According to the results obtained through the present investigation, it has been shown that there is a statistically significant effect between digital inclusion and satisfaction in university students in a condition of extreme poverty; in addition, the levels of satisfaction and user satisfaction maintain a close relationship of dependence. In the same way, that information search has a statistically significant relationship with digital inclusion, so does the exchange of information. Conversely, the exchange of digital information, the need for information, and the use of information would not positively influence the concept of digital inclusion according to the model proposed in the research.

REFERENCES

[1] L. Salas-Valdivia and O. Gutierrez-Aguilar, "Key factors for the success of connectivism in the elearning modality in the context of Covid-19," in *Proceedings - 2021 16th Latin American Conference on Learning Technologies, LACLO 2021*, 2021, pp. 368-371, doi: 10.1109/LACLO54177.2021.00044. [Online]. Available: <https://www.scopus.com/inward/record.uri?eid=2-s2.0-85127116466&doi=10.1109%2fLACLO54177.2021.00044&partnerID=40&md5=e1c8254fb7cd6307a70d51401c6b1a86>

[2] GobPePCM. "Sistema de Focalización de Hogares (SISFOH)." Gobierno del Perú - Presidencia del Consejo de Ministros. <https://www.gob.pe/437-sistema-de-focalizacion-de-hogares-sisfoh> (accessed).

[3] J. A. G. Gómez and J. L. S. Sánchez, "An analysis on information digital searching, access and discrimination processes in future school teachers |

Análisis de los procesos de búsqueda, acceso y selección de información digital en futuros maestros," *Digital Education Review*, no. 34, pp. 76-90, 2018.

[4] O. Gutierrez-Aguilar, J. Bautista-Lopez, E. Sanchez-Meza, and Y. Tomaylla-Quispe, "The role of the use of digital information in the performance and collaboration of university students in extreme economic situation," in *Proceedings - 2021 4th International Conference on Inclusive Technology and Education, CONTIE 2021*, 2021, pp. 23-29, doi: 10.1109/CONTIE54684.2021.00013. [Online]. Available: <https://www.scopus.com/inward/record.uri?eid=2-s2.0-85126704031&doi=10.1109%2fCONTIE54684.2021.00013&partnerID=40&md5=8f97c8347a790c5d735061993a400296>

[5] L. Villalustre Martínez and M. E. del Moral Pérez, "Webquest y Wikis: búsqueda de información en red y desarrollo de competencias en colaboración," (in Spanish), *Teoría de la Educación. Educación y Cultura en la Sociedad de la Información*, vol. 12, no. 1, pp. 190-208, 2011. [Online]. Available: <https://www.redalyc.org/articulo.oa?id=201021400010>.

[6] A. Morales Ramírez, J. D. Zacatenco Cruz, M. Luna Luna, R. Z. García Lozano, and C. Hidalgo Cortés, "Acceso y actitud del uso de Internet entre jóvenes de educación universitaria," *Revista Digital de Investigación en Docencia Universitaria*, vol. 14, no. 1, pp. 20-29, 2020, doi: 10.19083/ridu.2020.1174.

[7] I. Díaz-García, G. Almerich, J. Suárez-rodríguez, and N. Orellana, "La relación entre las competencias TIC , el uso de las TIC y los enfoques de aprendizaje en alumnado universitario de educación The relationship between ICT competences , ICT use and learning approaches in university students of education," vol. 38, pp. 549-566, 2020.

[8] D. Valverde-Crespo, A. de Pro-Bueno, and J. González-Sánchez, "Secondary students' digital competence when searching and selecting scientific information," *Enseñanza de las Ciencias*, vol. 38, no. 3, pp. 81-103, 2020, doi: 10.5565/REV/ENSCIENCIAS.2833.

[9] M. P. Prendes Espinosa and F. Cerdán Cartagena, "Tecnologías avanzadas para afrontar el reto de la innovación educativa," *RIED. Revista Iberoamericana de Educación a Distancia*, vol. 24, no. 1, pp. 35-53, 01/02 2021, doi: 10.5944/ried.24.1.28415.

[10] P. Cabello, J. M. Ochoa, and P. Felmer, "Tecnologías digitales como recurso pedagógico y su integración curricular en la formación inicial docente en Chile," *Pensamiento educativo*, vol. 57, pp. 1-20, 2020. [Online]. Available: http://www.scielo.cl/scielo.php?script=sci_arttext&pid=S0719-04092020000100109&nrm=iso.

[11] O. Gutiérrez-Aguilar and L. Salas-Valdivia, "Collaborative learning: The educational perspective of facebook," in *Proceedings - 14th Latin American Conference on Learning Technologies, LACLO 2019*, 2019, pp. 348-352, doi: 10.1109/LACLO49268.2019.00065. [Online]. Available: <https://www.scopus.com/inward/record.uri?eid=2-s2.0-85081124140&doi=10.1109%2fLACLO49268.2019.00065&partnerID=40&md5=6779b2c7f98fc0beb6710ed0cfaa5f5ce>

[12] O. G. Aguilar, M. Martinez Delgado, and F. P. Quispe, "Collaborative learning and its relationship with the classmates affective support with the COLLES questionnaire application," in *Proceedings of the 15th Latin American Conference on Learning Technologies, LACLO 2020*, 2020, doi: 10.1109/LACLO50806.2020.9381176. [Online]. Available: <https://www.scopus.com/inward/record.uri?eid=2-s2.0-85103739043&doi=10.1109%2fLACLO50806.2020.9381176&partnerID=40&md5=b75594119abc40dce36a05673d1a4def>

[13] I. L. Sajmolo *et al.*, "Comunidades sociales y la investigación por estudiantes universitarios," *Revista médica (Colegio de Médicos y Cirujanos de Guatemala)*, vol. 159, no. 1, pp. 18-22, 2020.

[14] J. García-Gutiérrez and M. Ruiz-Corbella, "Aprendizaje-servicio y tecnologías digitales: un desafío para los espacios virtuales de aprendizaje," *Revista Iberoamericana de Educación a Distancia*, vol. 23, no. 1, pp. 31-42, 2020.

[15] C. Matamala and J. E. Hinostroza, "Factores relacionados con el uso académico de Internet en educación superior," *Pensamiento educativo*, vol. 57, no. 1, pp. 1-19, 2020.

[16] O. Gutierrez-Aguilar, P. Escobedo-Maita, G. Calliñaua-Quispe, J. C. Vargas-Gonzales, and A. Torres-Huilla, "The use of social networks,

- usefulness and ease of use, enjoyment through positive emotions and their influence on school satisfaction mediated by school achievement," in *Iberian Conference on Information Systems and Technologies, CISTI*, 2022, vol. 2022-June, doi: 10.23919/CISTI54924.2022.9820347. [Online]. Available: <https://www.scopus.com/inward/record.uri?eid=2-s2.0-85134836560&doi=10.23919%2fCISTI54924.2022.9820347&partnerID=40&md5=37369fdebe0ca4de2d8cfd2f4da03c8e>
- [17] J. C. F. de la Iglesia, L. C. Otero, M. C. F. Morante, and B. Cebreiro, "Actitudes y uso de internet y redes sociales en estudiantes universitarios/as de Galicia: implicaciones personales y sociales," *Revista Prisma Social*, no. 28, pp. 145-160, 2020.
- [18] F. L. Pérez, M. C. Bas, and A. E. Nahón, "Autopercepción sobre habilidades digitales emergentes en estudiantes de Educación Superior," *Comunicar: Revista científica iberoamericana de comunicación y educación*, no. 62, pp. 91-101, 2020.
- [19] M. del Valle Tapia, J. V. Morales, A. B. B. Gutiérrez, A. E. D. Mujica, and I. G. Herrera, "Estudio de perfiles motivacionales latentes asociados con la satisfacción y autoeficacia académica de estudiantes universitarios," *Revista iberoamericana de diagnóstico y evaluación psicológica*, vol. 4, no. 57, pp. 137-147, 2020.
- [20] O. G. Aguilar and A. Gutierrez Aguilar, "A model validation to establish the relationship between teacher performance and student satisfaction," in *Proceedings - 2020 3rd International Conference of Inclusive Technology and Education, CONTIE 2020*, 2020, pp. 202-207, doi: 10.1109/CONTIE51334.2020.00044. [Online]. Available: <https://www.scopus.com/inward/record.uri?eid=2-s2.0-85105500381&doi=10.1109%2fCONTIE51334.2020.00044&partnerID=40&md5=7f2a14d18ebac7ddd56592c33610281f>
- [21] O. G. Aguilar, F. T. Apaza, and S. C. Huanca, "Influencing factors in perceived learning mediated by satisfaction in university students in times of Covid-19," in *Proceedings of the LACCEI international Multi-conference for Engineering, Education and Technology*, 2022, vol. 2022-July, doi: 10.18687/LACCEI2022.1.1.586. [Online]. Available: <https://www.scopus.com/inward/record.uri?eid=2-s2.0-85140021565&doi=10.18687%2fLACCEI2022.1.1.586&partnerID=40&md5=98a8ef7b45cae77bea5a4dcfa80b478a>
- [22] S. Bomi and Y. Cho, "Un análisis de los factores que afectan el rendimiento académico en un entorno globalizado," pp. 1-12, 2021.
- [23] M. Bobba and V. Frisnacho, "Self-perceptions about academic achievement: Evidence from Mexico City," *Journal of Econometrics*, no. January, 2020, doi: 10.1016/j.jeconom.2020.06.009.
- [24] M. A. Ali, K. Alam, B. Taylor, and S. Rafiq, "Does digital inclusion affect quality of life? Evidence from Australian household panel data," *Telematics and Informatics*, vol. 51, p. 101405, 2020.
- [25] H. J. Kim, P. Yi, and J. I. Hong, "Are schools digitally inclusive for all? Profiles of school digital inclusion using PISA 2018," *Computers & Education*, vol. 170, pp. 104226-104226, 2021, doi: 10.1016/j.compedu.2021.104226.
- [26] M. D. Alhassan and I. O. Adam, "The effects of digital inclusion and ICT access on the quality of life: A global perspective," *Technology in Society*, vol. 64, pp. 101511-101511, 2021, doi: 10.1016/j.techsoc.2020.101511.
- [27] B. Reisdorf and C. Rhinesmith, "Digital Inclusion as a Core Component of Social Inclusion," *Social Inclusion*, vol. 8, no. 2, pp. 132-137, 2020, doi: 10.17645/si.v8i2.3184.
- [28] R. E. Bawack and J. R. Kala Kamdjoug, "The role of digital information use on student performance and collaboration in marginal universities," *International Journal of Information Management*, vol. 54, p. 102179, 2020/10/01/ 2020, doi: <https://doi.org/10.1016/j.ijinfomgt.2020.102179>.
- [29] T. K. Dijkstra and J. Henseler, "Consistent partial least squares path modeling," *MIS quarterly*, vol. 39, no. 2, pp. 297-316, 2015.
- [30] R. P. Bagozzi and Y. Yi, "On the evaluation of structural equation models," *Journal of the academy of marketing science*, vol. 16, no. 1, pp. 74-94, 1988.
- [31] J. F. Hair Jr, G. T. M. Hult, C. M. Ringle, and M. Sarstedt, *A primer on partial least squares structural equation modeling (PLS-SEM)*. Sage publications, 2021.
- [32] C. Fornell and D. F. Larcker, "Evaluating structural equation models with unobservable variables and measurement error," *Journal of marketing research*, vol. 18, no. 1, pp. 39-50, 1981.
- [33] J. Hair and C. Ringle, "Partial least squares structural equation modeling: An emerging tool in research," *Retrieved September*, vol. 11, p. 2018, 2017.
- [34] J. Henseler, C. M. Ringle, and M. Sarstedt, "A new criterion for assessing discriminant validity in variance-based structural equation modeling," *Journal of the Academy of Marketing Science*, vol. 43, no. 1, pp. 115-135, 2015/01/01 2015, doi: 10.1007/s11747-014-0403-8.
- [35] A. Eroglu, O. K. Suzan, G. Hur, and N. Cinar, "The relationship between fear of COVID-19 and psychological resilience according to personality traits of university students: A PATH analysis," *Archives of Psychiatric Nursing*, vol. 42, pp. 1-8, 2023/02/01/ 2023, doi: <https://doi.org/10.1016/j.apnu.2022.11.001>.
- [36] J. Henseler, "Partial Least Squares Path Modeling," in *Advanced Methods for Modeling Markets*, P. S. H. Leeflang, J. E. Wieringa, T. H. A. Bijmolt, and K. H. Pauwels Eds. Cham: Springer International Publishing, 2017, pp. 361-381.