

Analysis of Temperature Controller in Thermal Chambers for Arbitrary References

Alex Mario Lerma Coaquira¹, Omar Chayña Velasquez², Julio Fredy Chura Acero², Norman Jesús Beltrán Castañón², Yony Alcides Mamani Mamani¹, Adhemir Homero Gutiérrez Gallegos² and Henry Shuta Lloclla²

¹ Ingeniería Mecánica Eléctrica, Universidad Nacional del Altiplano, Puno, Perú.
alerma@unap.pe yonyalcides@hotmail.com

² Ingeniería Mecánica Eléctrica, Universidad Nacional del Altiplano, Puno, Perú.
{ochayna, jchura, nbeltran, agutierrez, henryshuta}@unap.edu.pe

Abstract– *The temperature control of a thermoelectric module used in the construction of thermal cameras for the characterization of materials is proposed, including smart materials such as shape memory alloys, among others. A current amplifier controller model is used together with the corresponding model of the thermoelectric module and the thermal camera. This set is considered as a non-linear load with a variable impedance that must be controlled. In order to achieve effective temperature control, a temperature controller is implemented in the thermoelectric module designed in closed loop, thus ensuring the maintenance of the desired temperature. To measure the temperature in the thermoelectric module or in the chamber, a thermistor type sensor is used due to its fast response compared to other types of sensors. In the analysis of the temperature controller, various disturbances are taken into account, such as the ambient temperature that can vary between 15 and 35 degrees Celsius, the temperature range of the system between -10 and 100 degrees Celsius, the possibility of varying the impedance of the thermoelectric module, the delays produced in the thermistor response and the effect of the heat sink on the cooling temperature. A stability analysis is carried out for the temperature controller of the system in discrete time using the Root Locus method. The results of the transient response analysis demonstrate the effectiveness of the proposed controller. Simulations are presented showing how the system can cope with sudden or arbitrary temperature variations, and even follow sinusoidal references. This shows that it is possible to satisfactorily control the assembly consisting of the amplifier, the thermoelectric module and the thermal camera.*

Keywords– *Thermoelectricity, sensor, thermal chamber, temperature control, thermal hysteresis.*

I. INTRODUCTION

The physics of thermoelements has received considerable attention in these recent decades, due to which several investigations have been made. Carrying out some modifications with respect to the physical dimensioning, not counting on the main idea of transformation of calos has received little attention. This can be modified, since some recovery ability can be obtained with some certain modifications, as well as the use of some materials that perform the task of cooling.

Thermoelectric materials perform energy conversion. They have electrical and semiconductor properties and one of their applications would be the recovery of residual heat energy to later produce electricity or electrical energy. It is used in smaller-scale applications such as car seats, night vision systems, and electrical panel cooling. The more widespread use of thermoelectric requires not only improving the intrinsic validity of energy conversion of the elements, but also the recent implementation in terms of the structure.

In typical thermoelectric elements, a junction is formed from two conductive materials, one containing positive charge carriers (holes) and the other negative charge carriers (electrons). When an electric current is passed in the proper direction across the junction, both types of charge carriers separate from the junction and transfer heat, thus cooling the junction. Similarly, a heat source at the junction causes carriers to be directed away from the junction, analogous to a small generator. The devices have the advantage of not containing moving parts, but of low efficiencies, which makes them suitable for special applications, such as refrigeration of semiconductor elements. The principles of thermoelectric devices are reviewed and strategies are sought to increase the efficiency of new materials. Thermoelectric elements would not only help cool some technologies, but could also provide energy benefits in refrigeration and the use of waste heat to generate electrical power.

Several applications exist for TEM (thermoelectric module), including thermal chambers for controlled variation of arbitrary temperatures and the cooling of microelectronic devices, whose heat dissipation has been increasing in the direct proportion of work frequency. When it is necessary to vary the temperature to characterize a certain material, or the operation of precision instruments, it is clear the need to build a system of precise thermal cycling, in which the dynamic characteristics are well known. Therefore, in this work it is proposed a non-linear dynamic model for a TEM thermoelectric module, in conjunction with a thermal camera. for conditions specific, a simplified model for TEM is obtained and this model is used in the design of a temperature.

Digital Object Identifier: (only for full papers, inserted by LACCEI).
ISSN, ISBN: (to be inserted by LACCEI).
DO NOT REMOVE

To have an adequate control of the temperature in the TEM, it is necessary to have a control of the current that passes through the TEM. The TEM structure has been widely discussed in the literature [5] and [10]. as shown in Fig. 1, the device is composed of several semiconductors electrically connected in series and sandwiched between two plates of ceramics. When connected to a DC power supply, current flows through the elements producing the pumping heat from one side to the other [5] and [2]. As a consequence, this creates a side hot and a cold side. If the current is reversed, the pumping direction is reversed. Thus, the current flowing through the TEM is directly related to the temperature on both sides. The usual modeling of the device is based on the current, which requires the use of a current amplifier for the TEM. Current amplifiers currently used to control the TEM are class A or AB type. In the present work, a current amplifier of the type class D is used because it has advantages in size, efficiency and cost [7] and [8], in especially when the power involved is high. The structure of the thermal chamber used in this work, for the design of the temperature controller, is as shown in Fig. 1b. In this chamber, a hall effect sensor is used to measure the current flowing through the TEM and a sensor Thermistor type is used to measure temperature. The thermistor used has dimensions of less than 0.5 mm, which provides a faster response when compared to semiconductor sensors such as the LM35. the module the thermoelectric unit used is manufactured by HB Corporation model TEC1-12706, capable of withstanding a current 6.4A max, 16.4V max voltage, 57W max heat pumping capacity and resistance between 1.9 and 2.3 Ω . In vacuum, this module can achieve temperature differences of up to 75 degrees centigrade between the cold face and the hot face. As described, there is a non-linear dynamic that relates current and temperature. In this work, it is proposed a cascade controller [12] forming a double PID control loop to the two variables mentioned. For the design of such a controller, a stability analysis is performed using the method Geometric Place of Roots (LGR) [1], for the relationship between temperature and current in TEM, showing intervals in which, the system can reach instability. Analysis and simulation results are presented, showing the effectiveness of the controller.

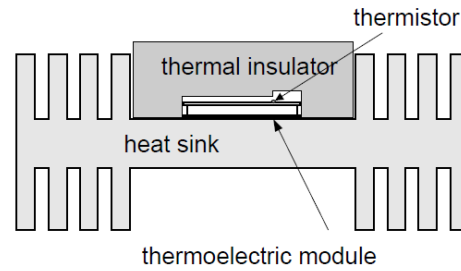

b)

Fig. 1. Thermoelectric module and thermal camera set (temperature sensor and hall effect sensor).

II. THERMAL CAMERA DYNAMICS MODEL

The heat balance equation is a key tool that allows us to understand how heat is transferred and distributed within a system. This equation establishes a balance between heat inputs and heat outputs in the system, allowing us to quantify changes in temperature and thermal energy. By using this equation, we can study and predict how a device will behave thermally under different conditions and optimize its design for optimum performance, equation [4] and [9]. The amount of heat Q [in J] stored in a body can be calculated through the following equation.

$$\frac{dQ}{dt} = (P_e - P_s) + (P_g - P_a) \quad (1)$$

Where P_e and P_s are the heat flux [in $J s^{-1} = W$] transported into and out of the body, respectively. In addition of the flux passing through the body, the heat fluxes P_g and P_a can be generated or absorbed respectively within of this body. The heat flow has a direct effect on the temperature change of the body in question. The magnitude and direction of this change will depend on several factors, such as the amount of heat transferred, the thermophysical properties of the body, and the heat transfer mechanisms involved. That modification can be shown by, the above equation can be written in the form.

$$C \frac{dT}{dt} = (P_e - P_s) + (P_g - P_a) \quad (2)$$

where $C = mc$ is the thermal capacitance of the body [in JK^{-1}], m mass of the body [in kg] and c its specific heat [in $Jkg^{-1}K^{-1}$]. Heat is transported through matter in its forms: conduction, convection and radiation. These processes are fundamental in heat transfer and play important roles in a wide range of situations and phenomena. These three heat transfer mechanisms are different and can occur simultaneously in many situations. The understanding of these processes is fundamental in fields such as thermal engineering, air conditioning of buildings, refrigeration, heat transfer in

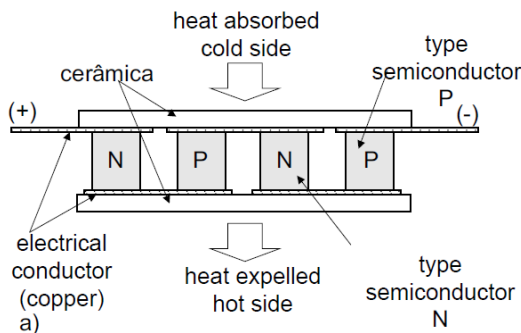

industry and many other applications related to the management and control of thermal energy. A flow \mathbf{P} between two bodies produces a temperature difference ΔT , which can be represented by the thermal conductance \mathbf{G} between them defined by.

$$G = \frac{P}{\Delta T}, [WK^{-1}] \quad (3)$$

In Fig. 2 The construction of a thermal camera requires the consideration of certain key characteristics and the measurement of specific magnitudes associated with it.

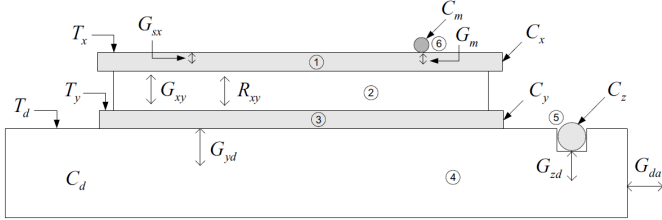

Fig. 2. Description of the thermal magnitudes of the plant. 1) TEM top plate; 2) Central layer of the TEM; 3) TEM bottom plate; 4) Heat sink; 5) Heat sink heating resistor; 6) Thermistor for temperature measurement.

When a current I_c passes through the TEM, the heat flux in the upper and lower plates are respectively given by [3], [6] and [11].

$$\begin{aligned} \frac{dQ_x}{dt} &= P_x - G_{xy}(T_x - T_y) \\ \frac{dQ_y}{dt} &= P_y + G_{xy}(T_x - T_y) \end{aligned} \quad (4)$$

where $G_{xy}(T_x - T_y)$ is the conduction heat flux between the upper and lower plates of the TEM and P_x and P_y the powers heat active, given by.

$$\begin{aligned} P_x &= I_c^2 \frac{R_{xy}}{2} + K_s T_x I_c \\ P_y &= I_c^2 \frac{R_{xy}}{2} - K_s T_x I_c \end{aligned} \quad (5)$$

for which R_{xy} is the electrical resistance between the upper and lower plates of the TEM [in Ohm] and K_s is the coefficient from seebeck [in $V K^{-1}$]. The term $I_c^2 R_{xy}$ is related to TEM heating by the Joule effect. half of this Joule power $I_c^2 R_{xy}/2$ is assigned to each of the cards. The terms $+ K_s T_x I_c$ and $- K_s T_x I_c$ are related to the peltier effect. If current flows in a certain direction such that $I_c > 0$, the top plate generates heat flux $K_s T_x |I_c|$ in addition to the Joule power $I_c^2 R_{xy}/2$ and causes an increase in temperature T_x . Simultaneously keeping $I_c > 0$, the board bottom absorbs a heat flux $-K_s T_x |I_c|$, added to the Joule power $I_c^2 R_{xy}/2$.

The bottom plate of the TEM was placed in thermal contact with a heat sink of much greater mass than the mass of TEM. In this way, the heat flux absorbed or generated on the bottom plate flows to the heatsink, maintaining thus the temperature T_y at an approximately constant value, equal to the heatsink temperature T_d . like the temperature T_y is kept constant as the temperature T_x increases when $I_c > 0$. This is the heating effect of the plate top of the TEM. If the direction of the current is reversed ($I_c < 0$) the upper plate of the TEM starts to absorb a flux of heat $-K_s T_x |I_c|$, added to the Joule power $I_c^2 R_{xy}/2$ which causes a reduction in temperature T_x with respect to T_d . At Fig. 3, shows the behavior of the active heat power P_x as a function of the current I_c in the TEM. In regions 1 and 3 the heat flux P_x generated at the top plate is positive, which causes an increase in temperature T_x . Note that in the region 3 even for current $I_c < 0$ the heat flux P_x can become positive, thus producing an increase in T_x . At region 2, the heat flux P_x is negative which causes a reduction in temperature T_x .

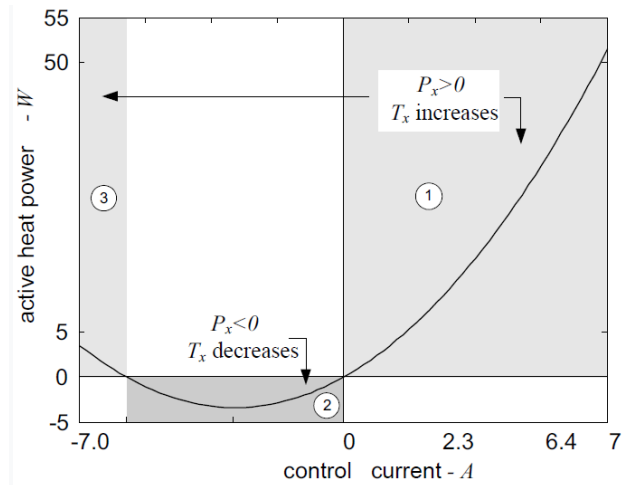

Fig. 3. Active heat power P_x as a function of the control current I_c in the TEM.

III. METODOLOGY

A. Controller Project

In Fig. 4, the general block diagram of the temperature controller is shown. The diagram shows that the system in its structure is composed of a current amplifier with internal loop controller $C_i(z)$, an order hold zero and quantizer that represent the transformation from discrete to continuous time in the form of PWM. The PWM output it is connected to the IGBT switches followed by the LC output filter. In the outer loop, a temperature controller $C_T(z)$ is designed in such a way to guarantee the desired temperature in the TEM. The TEM module is composed of P_{xy} that represents the nonlinear part described in equation (5). The temperature sensor used has a finite response time and transfer function given by.

$$H_m(s) = \frac{T_m(s)}{T_x(s)} = \frac{w_m}{s + w_m} \quad (6)$$

where w_m is the cut-off frequency of the temperature sensor

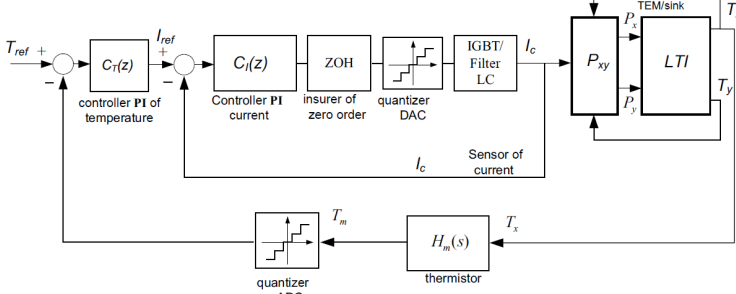

Fig. 4. Block diagram of the temperature controller in the TEM.

B. Current Controller and Amplifier

The temperature control design uses a current amplifier shown in Fig. 5. This amplifier is class D type and is composed of 4 IGBT switches and a low-pass LC output filter. IGBT switches are controlled using the Pulse Width Modulation (PWM) technique, as shown in Fig. 4. A Hall-effect current sensor is incorporated into the current amplifier structure to provide feedback. to the PI (Proportional Integral) controller. This feedback ensures that there is no error in the current output in the ThermoElectric Module (TEM). The type of current amplifier used in the temperature control design is highlighted, along with its specific configuration. The Pulse Width Modulation technique is used to control IGBT switches. Also, the incorporation of a Hall effect current sensor and PI controller to ensure accurate current output on the TEM, minimizing any errors in the temperature control process. In Fig. 5, the electrical model considered for the TEM is represented by the voltage V_{xy} in series with the resistance R_{xy} . The voltage V_{xy} depends on the temperature variation between the faces of the TEM and the seebeck coefficient, $V_{xy} = \alpha_m(T_x - T_y)$. The model that represents the TEM module is considered as presented below.

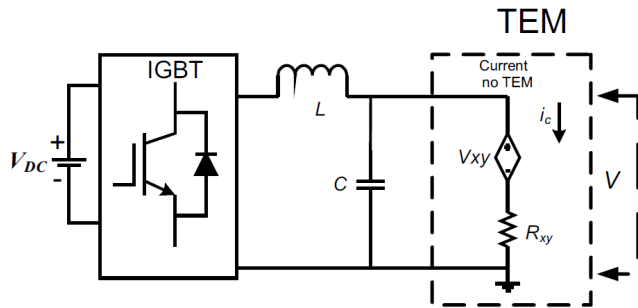

Fig. 5. Current amplifier model diagram.

C. Integral Proportional Controller

The whole temperature controller is analyzed in Fig. 6. In the figure, the current controller assembly and its respective power stage as shown in Fig. 4 has been simplified into a Current Amplifier block. In Fig. 6, the $C_T(z)$ temperature controller is designed in such a way to have a characteristic that compensates for the non-linear part described in equation (5) given by P_x . For the controller design, the waveform of the temporal variation of the temperature of reference $T_{ref}(t)$ is limited to triangular or sinusoidal types with period $T_{ref} = 2\pi/wr$, where wr is the frequency fundamental of the waveform. What is desired as a control objective is that the output signal $T_x(jw)$ must be a approximate copy of the reference signal $T_{ref}(jw)$: Therefore, the design in the frequency domain was initially chosen to define the structure and tuning of the controller. Thus, since $T_x(s) = T_{ref}(s)M_f(s)$; it is necessary to design a controller that makes the module $M_f(jw)$ equal to unity for a frequency range approximately equal to that of spectrum $T_{ref}(jw)$: Furthermore, it is necessary that the group delay $M_f(jw)$ be approximately constant in the frequency range of interest to avoid distortions in the $T_x(t)$ signal waveform. the control loop is given by.

$$M_f(s) = \frac{G(s)H_m(s)}{1 + G(s)H_m(s)} \quad (7)$$

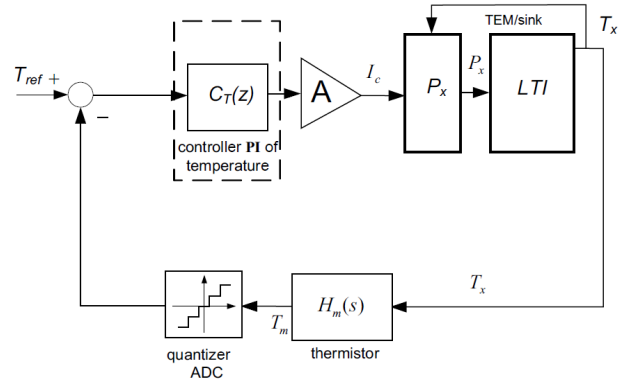

Fig. 6. temperature controller diagram $C_T(z)$.

An exhaustive analysis of the temperature control system was carried out under closed-loop conditions. The variation in the resistance R_{xy} of the TEM shown in the graph of Fig. 7 was considered, and the stability of the system was analyzed. In addition, the current amplifier and the temperature controller were also evaluated in detail. The analysis of the system using the external control loop allowed to demonstrate that the system is stable and capable of handling changes in the resistance of the TEM as shown in Fig. 7. This analysis is essential to guarantee the correct operation of the control system. temperature and the ability to maintain a desired temperature in the TEM.

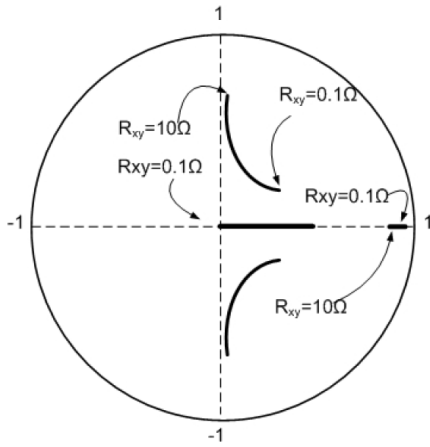

Fig. 7. LGR of closed-loop $C(z)F(z)$ temperature controller amplifier with load resistance variable R_{xy} from 0.1-10 Ω .

IV. RESULT AND DISCUSSION

To evaluate the effectiveness of the proposed controller, the signal shown was applied to the temperature control system, as illustrated in Fig. 9. It is evident that the controller responds quickly to correct and compensate for the desired temperature in the Thermoelectric Module (TEM) at time intervals less than 50 seconds. The ability of the controller to quickly adjust the temperature of the TEM as required is highlighted. The applied signal and its corresponding response demonstrate that the controller is capable of maintaining the desired temperature within acceptable limits in a short period of time. This rapid response is essential to ensure accurate and efficient temperature control, especially in situations where accurate and rapid thermal regulation is required to ensure proper operation of related systems or processes.

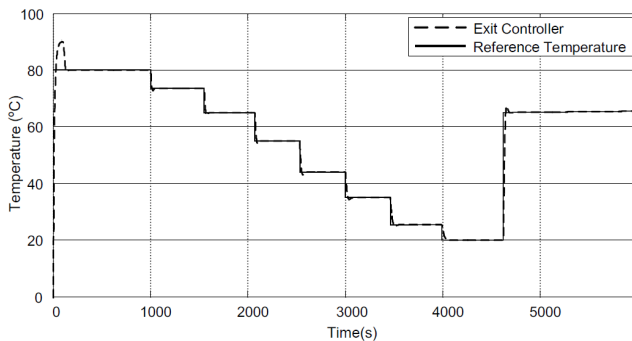

Fig. 8. Temperature detail for a given desired temperature range.

A sinusoidal waveform used as a reference for the controller is depicted in Fig. 9, along with the corresponding temperature in the Thermoelectric Effect Module (TEM). An impulse response of the current component driving the thermoelectric module is observed. This response is necessary

to raise the temperature from a given initial value of 30°C (room temperature) to 50°C, which is the initial value of the reference sinusoidal waveform. In this representation, the relationship between the sinusoidal waveform used as reference and the temperature in the TEM is highlighted. It is shown how the impulse response of the current component of the TEM allows reaching a specific temperature, in this case, raising it from the ambient temperature. This is essential to characterize certain materials at a given initial temperature and establish the necessary conditions to carry out measurements or analyzes in the desired temperature range.

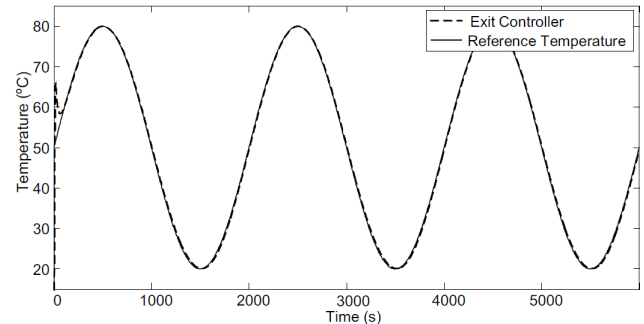

Fig. 9. Temperature detail for a given desired temperature range.

V. CONCLUSIONS

In this work, a nonlinear model for the temperature control of a Thermoelectric Effect Module (TEM) was proposed and implemented. An analysis of the current applied to the TEM was carried out and a class D amplifier was used as a current amplification model, due to its high efficiency compared to class A and AB amplifiers. A specific temperature controller for the TEM was designed and developed, considering its resistance variations. A stability analysis was performed, using the Locus of Roots (LGR), in comparison with the traditional method that varies the feedback gain. In this case, the feedback gain was kept constant and the resistance of the TEM was varied. The proposed system was subjected to analysis with temperature variations in wide ranges, demonstrating its ability to follow the desired temperature changes. The simulation results are presented, which show the effectiveness of the proposed controller.

REFERENCES

- [1] Abusara, M.A. and Sharkh, S.M., 2013. "Design and control of a grid-connected interleaved inverter". IEEE Transactions on Power Electronics, pp. 748–764. Vol. 28.
- [2] Almeida, L.A.L., 2003. "Modelo de histerese para transição semiconductor-metal em filmes finos de vo2". Technical report, UFPB, Campina Grande, Paraíba, Brasil.
- [3] Chávez, J.A., Ortega, J.A., Salazar, J., Turó, A. and García, M.J., 2000. "Spice model of thermoelectric elements including thermal effects". 17th IEEE Instrumentation and Measurement Technology Conference - IMTC.

- [4] Dalola, S., Ferrari, M., Ferrari, V., Guizzetti, M., Marioli, D. and Taroni, A., 2009. "Characterization of thermoelectric modules for powering autonomous sensors". IEEE Transactions on Instrumentation and Measurement. Vol. 58.
- [5] Holes, M., 2012. "Optimal design of thermoelectric refrigerators embedded in a thermal resistance network". IEEE Transactions on Components, Packaging and Manufacturing Technology, pp. 483–495. Vol. 2.
- [6] Huang, B.J. and Duang, C.L., 2000. "System dynamic model and temperature control of a thermoelectric cooler". International Journal of Refrigeration, pp. 197–207.
- [7] Jae, H.J., Gue, H.K., Byeong, R.M., Che, H.A. and Gyu, H.C., 1997. "A high efficiency class a amplifier accompanied by class d switching amplifier". 28th Annual IEEE Power Electronics Specialists Conference, 1997. PESC '97 Record.
- [8] Kamper, M., Ulbricht, G., Weigel, R. and Fischer, G., 2011. "Comparison of class a and class d rf amplifier operation with focus on reverse intermodulation and efficiency performance". In ProcEEEngineering. European Microwave Integrated Circuits Conference (EuMIC).
- [9] Meijer, G. and Herwaarden, A., 1994. "Thermal sensors". IOP Publishing.
- [10] Mona, Z. and Chen, G., 2011. "Recent advances in thermoelectrics". IEEE International Electron Devices Meeting.
- [11] Rowe, D.M., 1995. "Crc handbook of thermoelectrics". CRC Press.
- [12] Thanana, N. and Thananchai, L., 2013. "Control of metal hydride reactor coupled with thermoelectric module via fuzzy adaptive pid controller". IEEE/ASME International Conference on Advanced Intelligent Mechatronics